

THIS DRAWING IS UNPUBLISHED. RELEASED FOR PUBLICATION
 © COPYRIGHT - By - ALL RIGHTS RESERVED.

LOC		DIST		REVISIONS			
P	LTR	DESCRIPTION		DATE	DWN	APVD	
AJ	17	G1	REVISED PER ECO-11-005030		11MAR11	RK	HMR

- USE INSTRUCTION SHEET 408-2187.
- ACCOMMODATES 0.79 [.031] TO 4.78 [.188] PANEL THICKNESS.

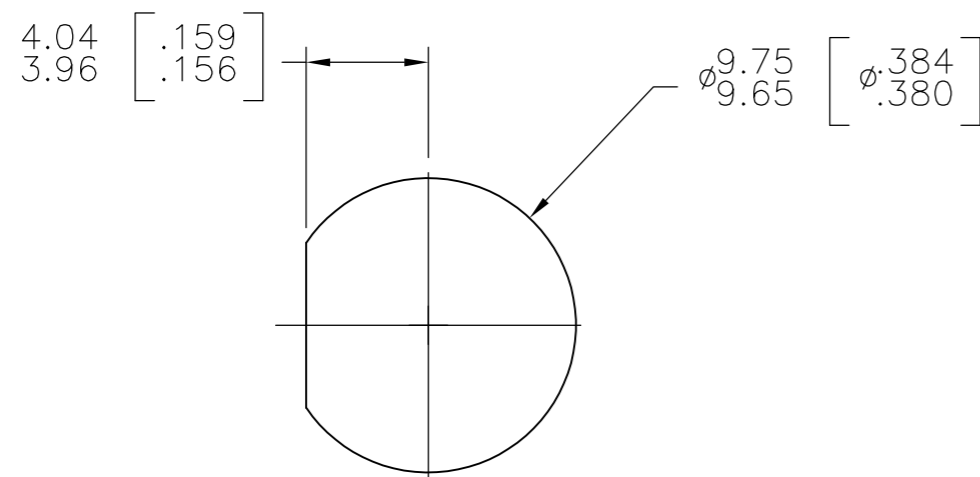
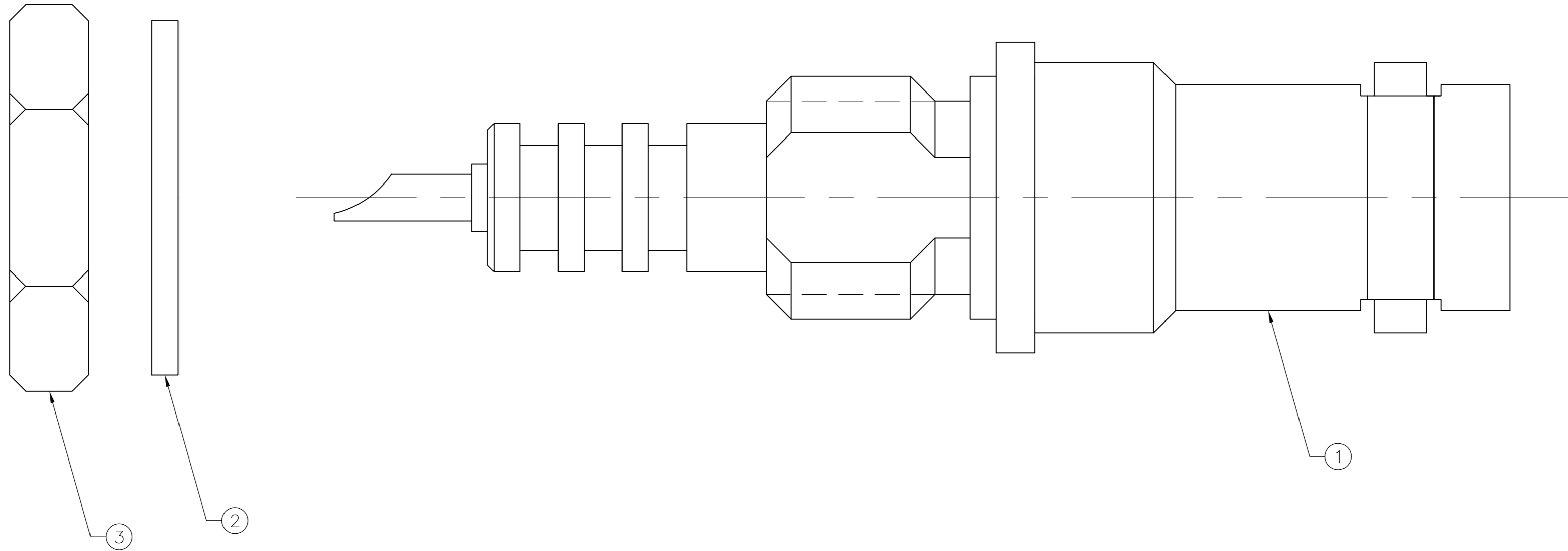

RECOMMENDED PANED CUTOUT
SCALE 4:1

.461 oz	1-330249-1	1-329492-1	51531-2	51494-2
.423 oz	9-330249-0	9-329492-0	9-51531-0	51494-1
WEIGHT	③ JAM NUT QTY: 1	② LOCK WASHER QTY: 1	① JACK ASSEMBLY QTY: 1	PART NUMBER

THIS DRAWING IS A CONTROLLED DOCUMENT.		DWN D. WALLACE	OBJAN08	STE TE Connectivity	
DIMENSIONS: mm [INCHES]		CHK J. LIPPERT	OBJAN08		
TOLERANCES UNLESS OTHERWISE SPECIFIED:		APVD J. LIPPERT	OBJAN08	NAME SHV BULKHEAD SOLDER JACK	
0 PLC ± -		PRODUCT SPEC		SIZE	
1 PLC ± -		APPLICATION SPEC		CAGE CODE	
2 PLC ± 0.41[.016]		WEIGHT		DRAWING NO	
3 PLC ± -		MATERIAL		RESTRICTED TO	
4 PLC ± -		FINISH		SCALE	
ANGLES ± -		CUSTOMER DRAWING		SHEET	
FINISH		A2 00779		REV	
MATERIAL		G1		REV	